

oOh!media Site Specifications

Study Classic



Study Classic Unilite

Specifications:

Format: PDF

File Scale and Quality: 100dpi at 100% scale.

Dimensions

Visual Size: 1150mm (w) x 1750mm (h)

Finish Size: 1175mm (w) x 1775mm (h)

Stock: 158gsm Synthetic Paper (Yupo)

Colour Mode: CMYK

Additional Guidelines:

- There is zero tolerance on finish size. Images outside the visual safe area will be covered by the lightbox frame.
- Please ensure OVERPRINT is turned OFF in your print files. If OVERPRINT is left ON, this could lead to print issues.
- No registration marks or crop marks inside the finished area.

Delivery

All files must be clearly labelled, as per the example below:

- CTNumber_Advertiser_CreativeDescription_File#of#_PixelRatio.EXT
- If multiple creatives are being provided, there must only be 1 creative per document.

Please submit files to your Campaign Delivery Executive.

Deadlines

For clients using oOh!media print production service, all artwork is required 10 business days (2 weeks) prior to live date.

Printed material is due to installers 5 business days (1 week) prior to live date.

All material must be approved prior to print and display by your Campaign Delivery Executive.

Late delivery of files may result in missed media time.

Questions? Need more information?

Please contact your Campaign Delivery Executive.

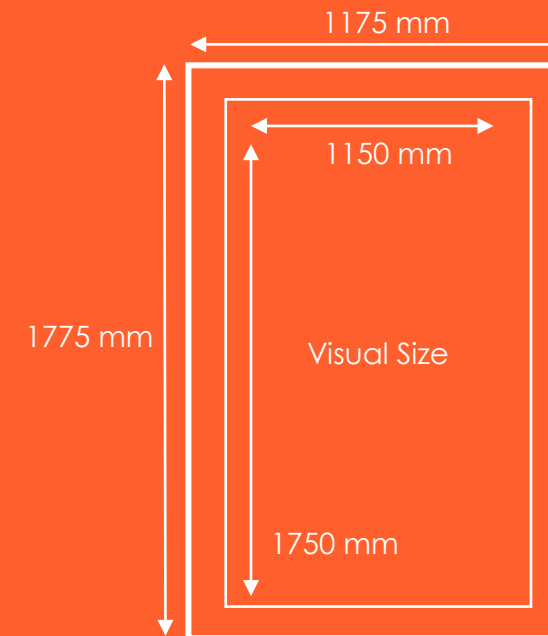

Study Classic Unilite-M

Specifications:

Format: PDF

File Scale and Quality: 100dpi at 100% scale.

Dimensions:

Visual Size: 1110 mm (w) x 1700 mm (h)

Finish Size: 1150 mm (w) x 1740 mm (h)

Stock: 158gsm Synthetic Paper (Yupo)

Colour Mode: CMYK

DPI: 300

Additional Guidelines:

- There is zero tolerance on finish size. Images outside the visual safe area will be covered by the lightbox frame.
- Please ensure OVERPRINT is turned OFF in your print files. If OVERPRINT is left ON, this could lead to print issues.
- No registration marks or crop marks inside the finished area.

Delivery

All files must be clearly labelled, as per the example below:

- CTNumber_Advertiser_CreativeDescription_File#of#_PixelRatio.EXT
- If multiple creatives are being provided, there must only be 1 creative per document.

Please submit files to your Campaign Delivery Executive.

Deadlines

For clients using oOh!media print production service, all artwork is required 10 business days (2 weeks) prior to live date.

Printed material is due to installers 5 business days (1 week) prior to live date.

All material must be approved prior to print and display by your Campaign Delivery Executive.

Late delivery of files may result in missed media time.

Questions? Need more information?

Please contact your Campaign Delivery Executive.

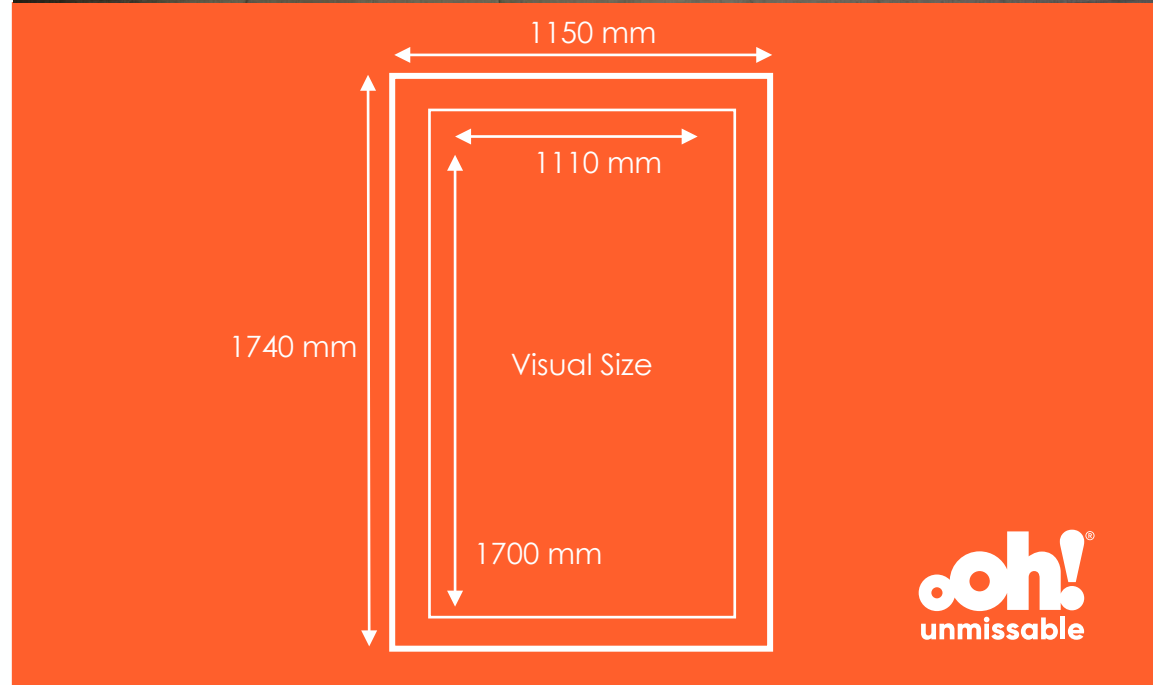

ooh![®]
unmissable

Sydney

T +61 (2) 9927 5555
Level 2, 73 Miller Street
North Sydney NSW 2060

Melbourne

T +61 (3) 8598 0700
Level 3, 101 Moray Street
South Melbourne VIC 3205

Brisbane

T +61 (7) 3620 2900
2/89 McLachlan Street
Fortitude Valley QLD 4006

Adelaide

T +61 (8) 8367 3222
Level 4, 149 Flinders Street
Adelaide SA 5000

Perth

T +61 (8) 6160 8999
344 Hay Street
Subiaco WA 6008

Auckland

T +64 (9) 337 5595
22 Pollen Street,
Grey Lynn AK 1024
New Zealand