

oOh!media Site Specifications

## Study Classic



# Study Classic Unilite

## Specifications:

**Format:** PDF

**File Scale and Quality:** 100dpi at 100% scale.

### Dimensions

**Visual Size:** 1150mm (w) x 1750mm (h)

**Finish Size:** 1175mm (w) x 1775mm (h)

**Stock:** 158gsm Synthetic Paper (Yupo)

**Colour Mode:** CMYK

### Additional Guidelines:

- There is zero tolerance on finish size. Images outside the visual safe area will be covered by the lightbox frame.
- Please ensure OVERPRINT is turned OFF in your print files. If OVERPRINT is left ON, this could lead to print issues.
- No registration marks or crop marks inside the finished area.

### Delivery

All files must be clearly labelled, as per the example below:

- CTNumber\_Advertiser\_CreativeDescription\_File#of#\_PixelRatio.EXT
- If multiple creatives are being provided, there must only be 1 creative per document.

Please submit files to your Campaign Delivery Executive.

### Deadlines

For clients using oOh!media print production service, all artwork is required 10 business days (2 weeks) prior to live date.

Printed material is due to installers 5 business days (1 week) prior to live date.

All material must be approved prior to print and display by your Campaign Delivery Executive.

Late delivery of files may result in missed media time.

### Questions? Need more information?

Please contact your Campaign Delivery Executive.

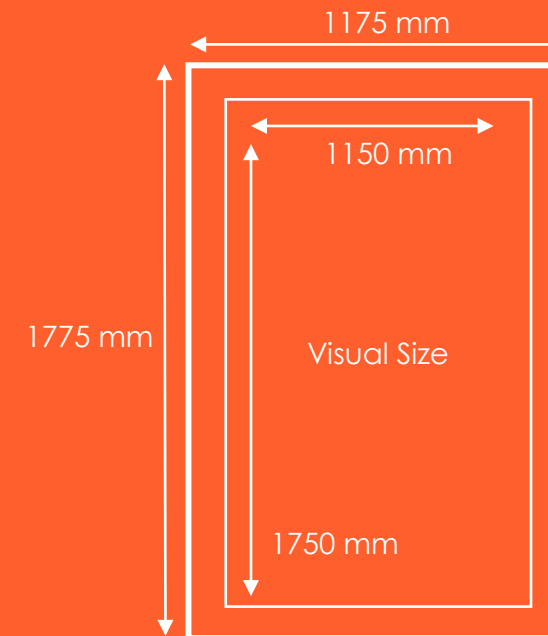

# Study Classic Unilite-M

## Specifications:

**Format:** PDF

**File Scale and Quality:** 100dpi at 100% scale.

**Dimensions:**

**Visual Size:** 1110 mm (w) x 1700 mm (h)

**Finish Size:** 1150 mm (w) x 1740 mm (h)

**Stock:** 158gsm Synthetic Paper (Yupo)

**Colour Mode:** CMYK

**DPI:** 300

### Additional Guidelines:

- There is zero tolerance on finish size. Images outside the visual safe area will be covered by the lightbox frame.
- Please ensure OVERPRINT is turned OFF in your print files. If OVERPRINT is left ON, this could lead to print issues.
- No registration marks or crop marks inside the finished area.

## Delivery

All files must be clearly labelled, as per the example below:

- CTNumber\_Advertiser\_CreativeDescription\_File#of#\_PixelRatio.EXT
- If multiple creatives are being provided, there must only be 1 creative per document.

Please submit files to your Campaign Delivery Executive.

## Deadlines

For clients using oOh!media print production service, all artwork is required 10 business days (2 weeks) prior to live date.

Printed material is due to installers 5 business days (1 week) prior to live date.

All material must be approved prior to print and display by your Campaign Delivery Executive.

Late delivery of files may result in missed media time.

## Questions? Need more information?

Please contact your Campaign Delivery Executive.

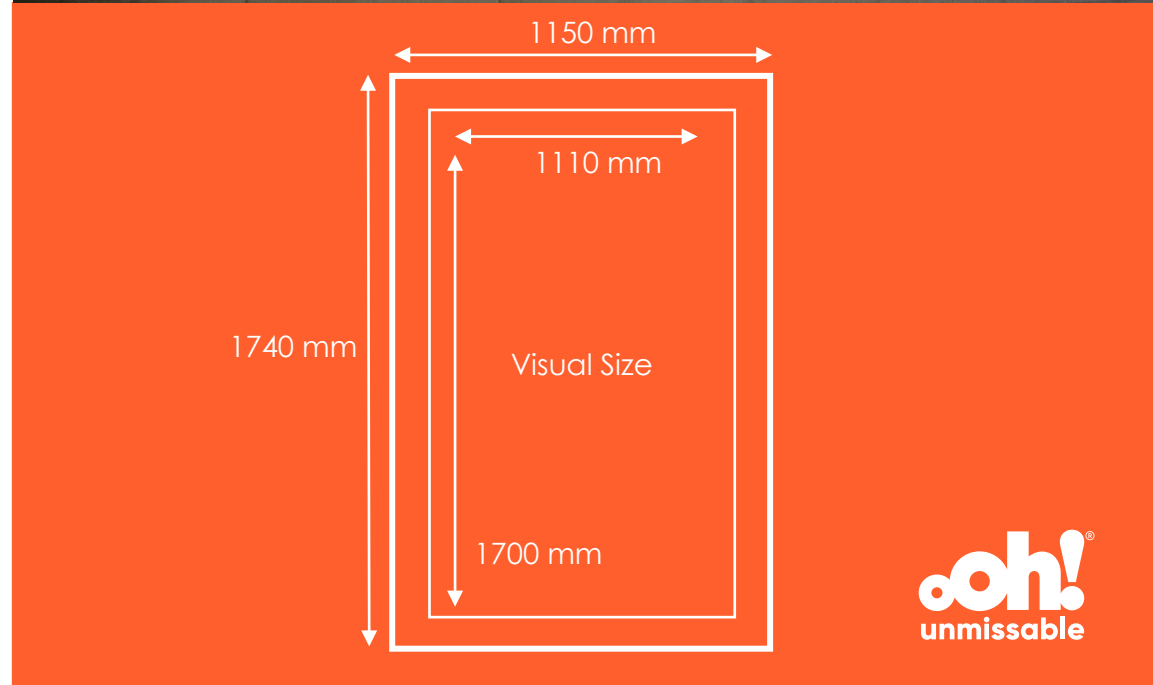

**ooh!**<sup>®</sup>  
**unmissable**

**Sydney**

**T +61 (2) 9927 5555**  
Level 2, 73 Miller Street  
North Sydney NSW 2060

**Melbourne**

**T +61 (3) 8598 0700**  
Level 3, 101 Moray Street  
South Melbourne VIC 3205

**Brisbane**

**T +61 (7) 3620 2900**  
2/89 McLachlan Street  
Fortitude Valley QLD 4006

**Adelaide**

**T +61 (8) 8367 3222**  
Level 4, 149 Flinders Street  
Adelaide SA 5000

**Perth**

**T +61 (8) 6160 8999**  
344 Hay Street  
Subiaco WA 6008

**Auckland**

**T +64 (9) 337 5595**  
22 Pollen Street,  
Grey Lynn AK 1024  
New Zealand